

ENGINEER TO ORDER

SPECIAL PROJECT INFORMATION SHEET



Project Description	Offset gearbox for PTM-52		
Date created	December 2016	Project Number	Q3949

INTRODUCTION & APPLICATION

Commercial vehicle trailer manufacturer requires improved tooling to torque tighten various axle assembly M24 bolts, where access is restricted.

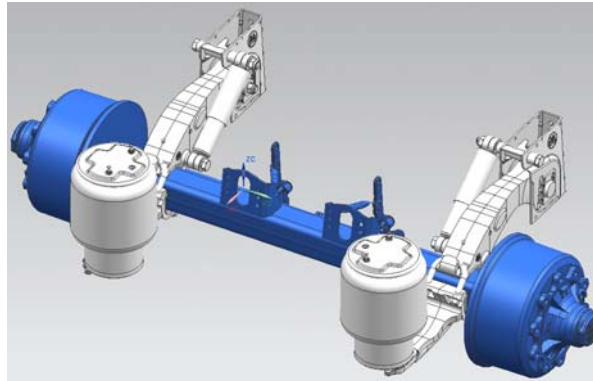

SOLUTION

Pneutorque PTM-52-800-B fitted with a 4-gear offset gearbox having integral post & lug reactions to suit the various applications, operating at 550 N.m typical torque.

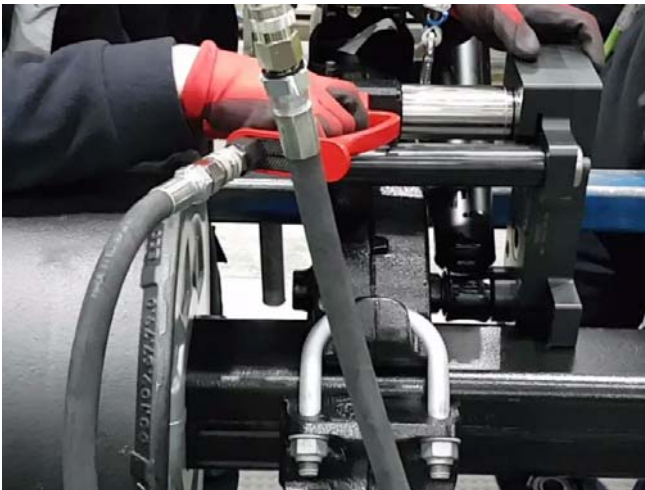

TECHNICAL SPECIFICATION / DATA HIGHLIGHTS

4-gear offset gearbox having 205.74mm offset distance and 800 N.m maximum torque capacity.
36mm female hexagon output drive, with 1:1 (*nominal*) torque ratio.
13.0 Kg approx. weight with Xylan coated steel casings, and hardened steel gears running in bearings.